

Many system configurations require multiple transducers to be normalized for gain or offset, prior to further A to D conversion or signal processing. The Intersil X9241A quad XDCPs can provide an elegant and efficient solution for performing these tasks under microprocessor control.

The configuration in Figure 1 shows two dual op amps being controlled by a single quad XDCP. The gain range in this configuration can be trimmed between -0.5 to -2.0 over 64 steps. Increasing R5 and R6 (the feedback determining network in U2a for example) to 100kΩ will change the gain trim range to between -0.91 to -1.1. The inverting configuration shown is particularly suitable as this allows input signals to vary from ±6V without violating the digital pots terminal voltage specifications of ±5V/-3V.

An offset trimming configuration is shown in Figure 2 for the same pair of dual op amps. This configuration yields an offset trimming range of ±300mV over 64 steps. The offset range can be increased or decreased by changing the value of R13 (in amplifier U2a for example). Changing R13 to 1mΩ will decrease the offset range to ±40mV if finer resolution, but less range is desired. This configuration also ensures

that the X9241A is operating within the specified terminal voltage range of less than ±5V/-3V.

## Potpourri Amplifier

Figure 3 illustrates a microprocessor controlled circuit that can provide adjustable gain from -1 to infinity with two of the pots of the quad X9241AW XDCP. The other two pots can be ganged together using the cascade mode for extended offset range. The purpose of this circuit is not to solve a particular analog signal processing problem, but rather to demonstrate the analog control flexibility that can be attained with the X9241A.

With R2 set to 0 and R1 set to 63, the overall gain from input to output will be -1. Gain values in the range 0 to -1 can be set over 64 steps by incrementing the value of R1. Setting R1 back to 0 and setting R2 to 32 results in an overall gain of +1. Increasing R2 to 63 yields a gain of plus infinity. This is essentially a positive comparator with the threshold level being set by the cascade combination of R0 and R3. National Semiconductor's LMC6482 is a nice amplifier for this application because of its rail-to-rail input and output range.

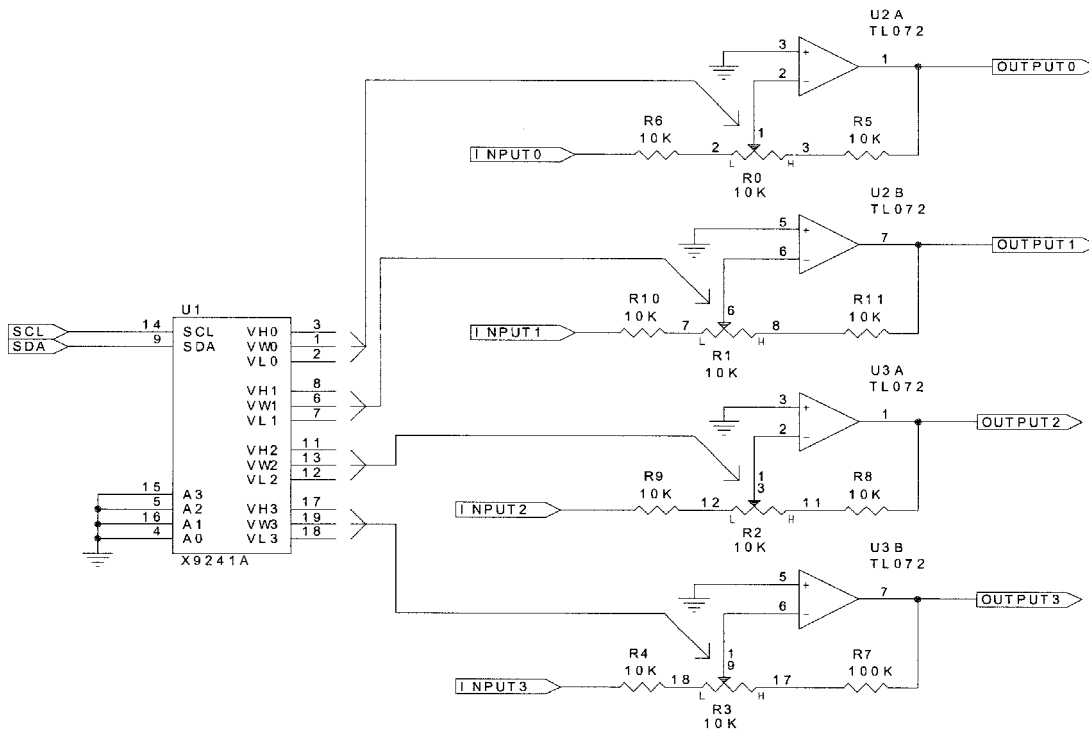

FIGURE 1. X9241A CONTROLLED GAIN ADJUST

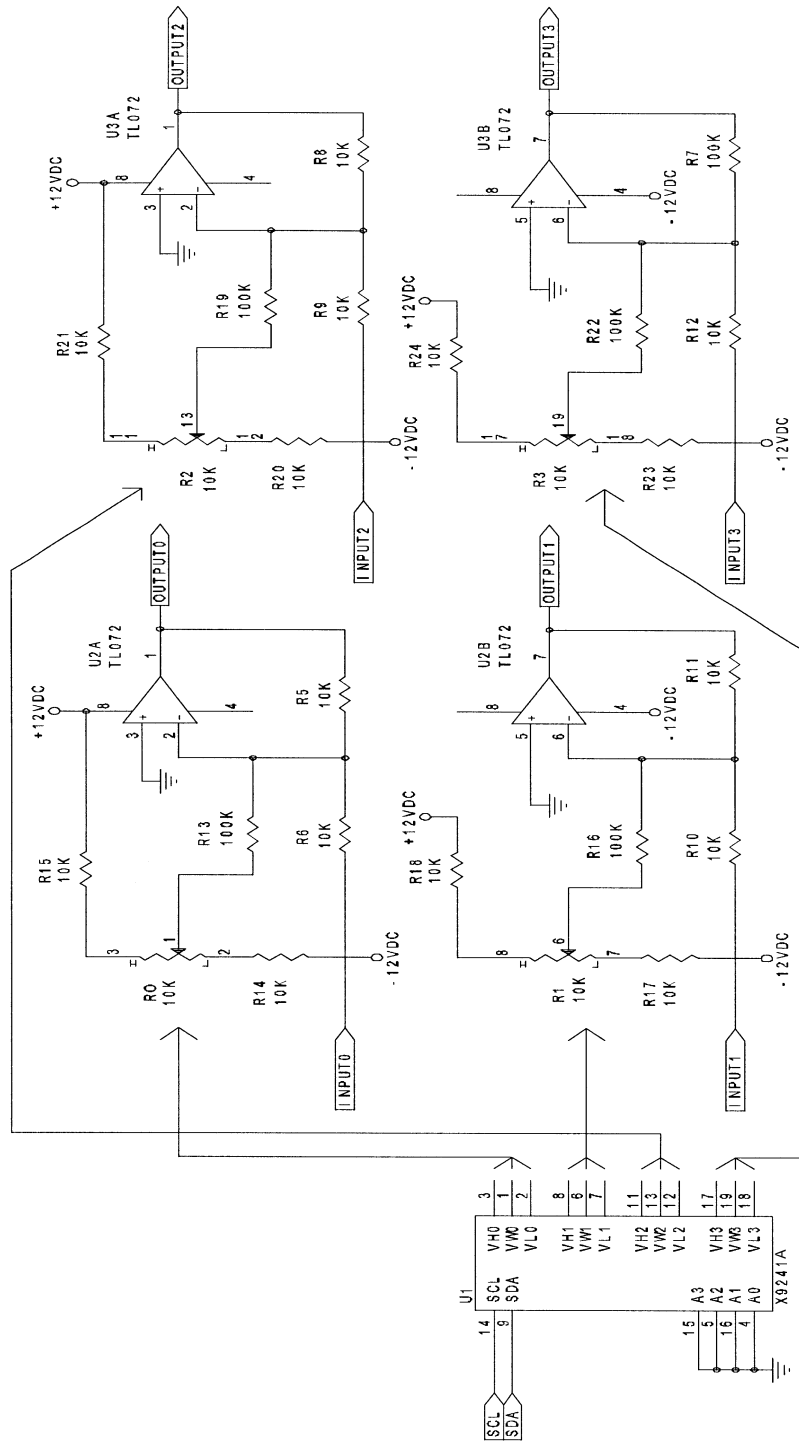

FIGURE 2. X9241A CONTROLLED OFFSET ADJUST

# Application Note 50

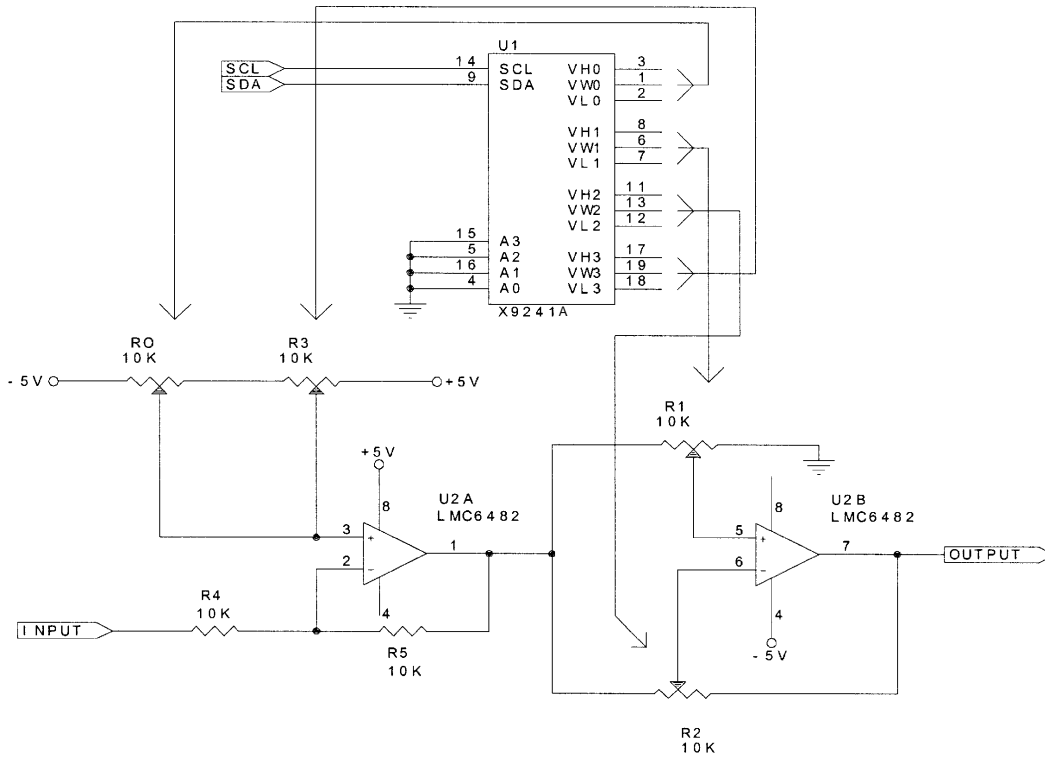

FIGURE 3. EXTENDED RANGE GAIN ADJUST

Intersil Corporation reserves the right to make changes in circuit design, software and/or specifications at any time without notice. Accordingly, the reader is cautioned to verify that the Application Note or Technical Brief is current before proceeding.

For information regarding Intersil Corporation and its products, see [www.intersil.com](http://www.intersil.com)